

PUBLIC ADDRESS / SPEAKERS / SURFACE

# SONORA-3TN

100 V LINE TRANSFORMER AND LOW IMPEDANCE SURFACE SPEAKER



- ✓ Crisp, distortion-free sound
- ✓ Excellent finish and elegant design
- ✓ Quick and easy installation

ESPECIALLY RECOMMENDED IN:



Hospitality



Education



Hotels



All sectors



+ Info:

<https://fonestar.com/SONORA-3TN>

## DESCRIPTION

Sound reinforcement loudspeaker with 100 V line transformer and low impedance. Based on our extensive experience in the sound sector, FONESTAR has created SONORA. SONORA is a series of loudspeakers especially designed for PA and background sound applications. Its excellent finish and elegant design allow perfect integration in any space. Besides, SONORA delivers high sound quality with clear, distortion-free sound. They include all the necessary accessories for quick and easy installation: swivel mount and screws. For public address and ambient sound applications in public places such as restaurants, cafés, supermarkets, shopping centres, etc.

## TECHNICAL CHARACTERISTICS

FEATURES	Sound reinforcement loudspeaker with 100 V line transformer and low impedance.
POWER	20 W max., 12 W RMS
LOUDSPEAKERS	1 x 3" woofer
RESPONSE	130-20,000 Hz
IMPEDANCE	12 W RMS@100 V (833 Ohm) Low Z: 8 Ohm
SENSITIVITY	84 dB @ 1 W/1 m
MAXIMUM SOUND PRESSURE	94 dB @ max. W/1 m
COVERAGE ANGLE	H/V: 270°/270°@500Hz, 180°/180°@1kHz, 120°/120°@2kHz, 100°/100°@4kHz (-6 dB)
MATERIAL	ABS (UV resistance) Aluminium mesh grille, with powder-coated finish Weather-resistant mount Stainless steel screws
SWITCH	High Z and low Z selector
CONNECTORS	Euroblock in and out for cable 0.25 - 2.5 mm <sup>2</sup> cross section
TEMPERATURE RANGE	-10°C ~ 60°C
COLOUR	Black (RAL 9005)
DIMENSIONS	Loudspeaker: 97 x 110 x 107 mm depth Mount wall plate: 67 x 71 mm Loudspeaker with mount: 150 mm depth
WEIGHT	0.7 kg
ACCESSORIES	Adjustable fixing mount H: ±30°, V: +15°/-45°



+ Info:

<https://fonestar.com/SONORA-3TN>

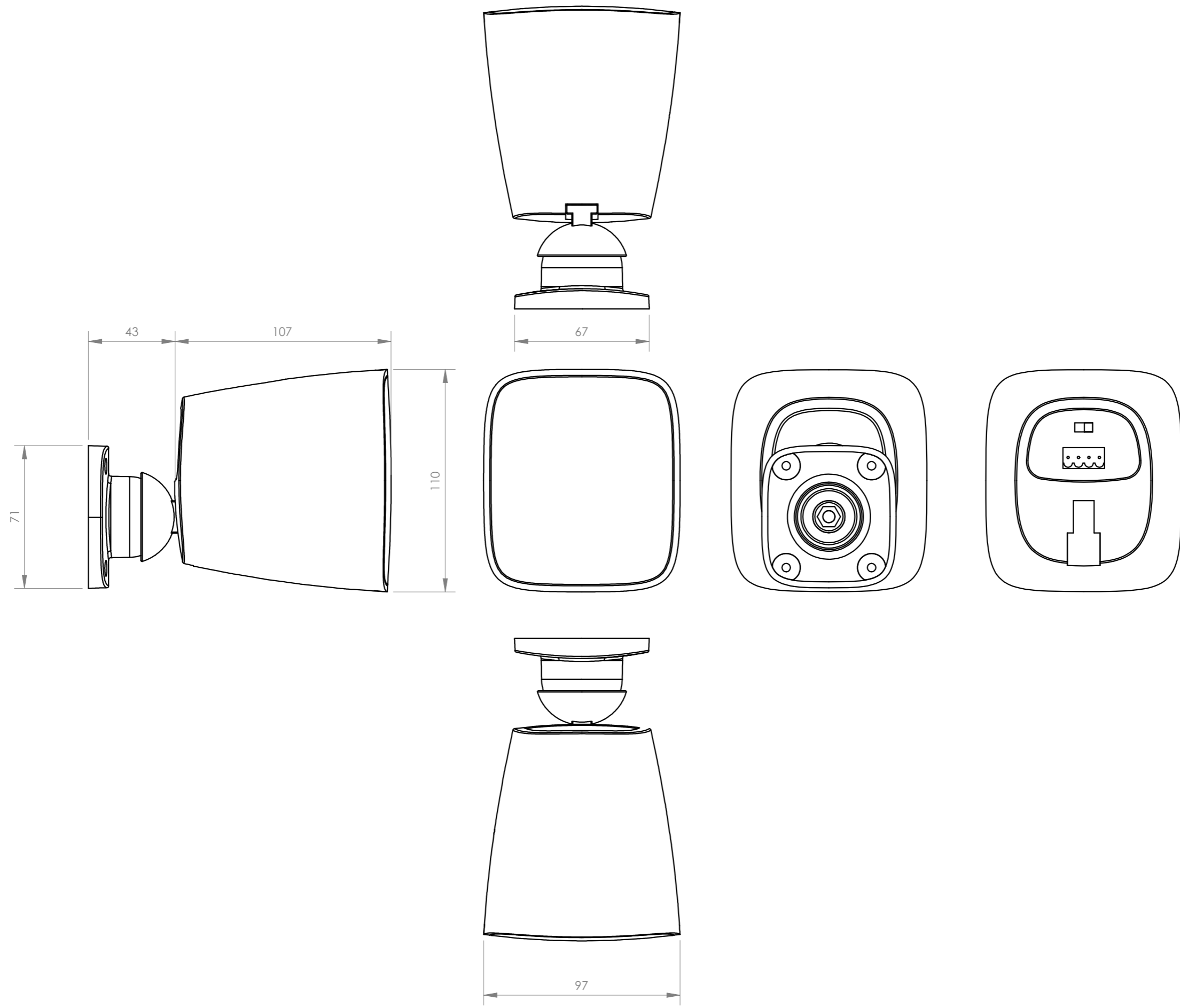

<b>FONESTAR</b>	Model	Description	Units	Scale
	SONORA-3TB+SONORA-3TN	100 V LINE TRANSFORMER AND LOW IMPEDANCE SURFACE SPEAKER	mm	1:2